

SP-G SERIES

Product features

- integrated cast steel rectangular guideway, mechanical rigidity and toughness and can withstand greater pressure and impact force. Ordinary press machine body was made by cast iron, no toughness, pressure is too large or collision will break.
- the press stroke can be adjusted, can be customized as special requirements.
- handle and spindle with spline connection, can be adjusted at any angle.
- has function of prevent rotation when press machine down the process.
- CNC processing and molding, higher accuracy.

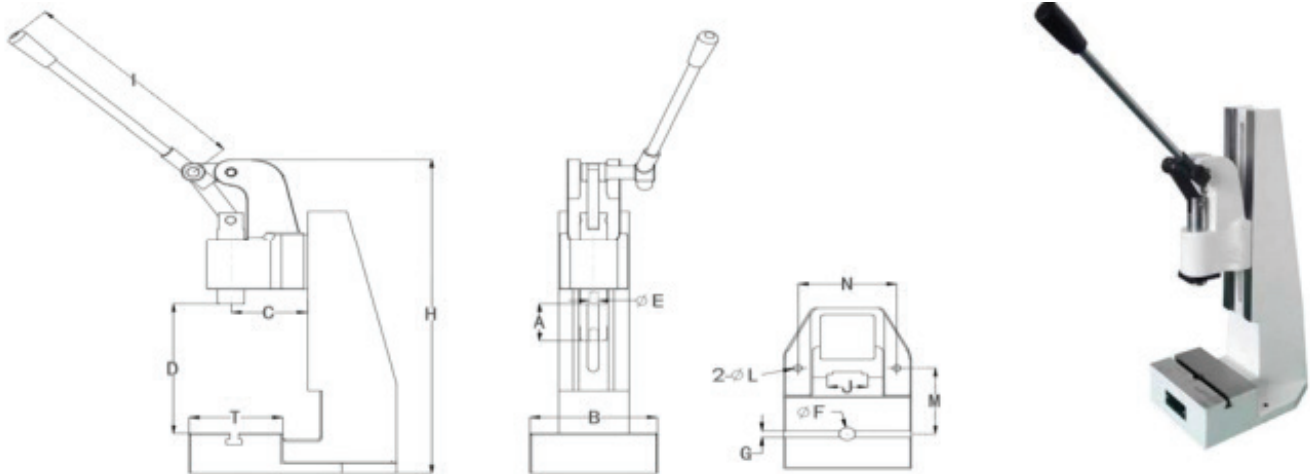

Model	Pressure KN	A	B x T	C	D	E	F	G	H	Weight Kg
		Travel mm	Table Size mm	Spindle Span mm	Height Adjust mm	Install Aperture mm	Table Aperture mm	T Slot Width mm	Machine Height mm	
SP-G1	15	0-45	150 x 110	86	80 - 210	10 H7	20 H7	10	444	23
SP-G2	15	0-60	150 x 110	86	80 - 265	10 H7	20 H7	10	494	25
SP-G3	15	0-60	185 x 115	86	120 - 360	10 H7	20 H7	10	604	31

